



REAL TIME CROSS CORRELATION



RoHS

HA7062D

PHASE NOISE ANALYZER

10MHz to 26GHz

Optional to 40GHz

Cross Correlation

Real Time Data Acquisition

PRELIMINARY DATA SHEET



4TECT

Телефон: +7 (499) 685-4444
info@4test.ru
www.4test.ru

PRODUCT SUMMARY

The **HA7062D Real Time Phase Noise Analyzer** is born from Holzworth's history of industry leading phase noise analyzers with proven accuracy, high reliability, automation and flexibility. The real time engine covers the full measurement bandwidth with extremely fast measurement speeds to reduce product development time and optimizes ATE manufacturing throughput.

MEASURED NOISE FLOORS: Like the HA7062D, competitive designs provide a *measurement confidence factor*, which is often misinterpreted as the noise floor of the instrument. Holzworth is the only company that has architected the instrument's front end so that the noise floors limits can actually be measured (refer to pages 7-10).

UNPARALLELED ANALOG PERFORMANCE: The HA7062D has high speed digital processors for speed, but the proven accuracy and speed starts with the analog front end. A key component of the analog front end is a pair of Holzworth HSX Series RF Synthesizers as the test system's internal LOs. These ultra low noise RF sources not only complement the dual core FFT engine to provide one of the most advanced phase noise analyzers available, but they are also made available to the user at the front panel's *LO Output* ports.

REPEATABLE DATA: Holzworth's fully shielded, fan-less 1U chassis eliminates ground loops and troublesome microphonics for uncompromised performance and repeatability. See it for yourself knowing that Holzworth encourages running head-head tests with the competition. Contact Holzworth directly for availability of an evaluation unit in your area.

REAL TIME FULL BANDWIDTH DATA ACQUISITION

ANSI Z540 CALIBRATED ACCURACY 0.1Hz - 100MHz

VERSATILE - RECONFIGURABLE FRONT END

MEASURE: PM / AM / BASEBAND / SPURIOUS / JITTER / PULSE

SIMULTANEOUS/ ISOLATED AM/PM MEASUREMENTS

AUTOMATED RESIDUAL MEASUREMENTS

MEASURABLE ULTRA LOW PHASE NOISE FLOORS

3 YEAR MANUFACTURER WARRANTY



PRODUCT SUMMARY - BLOCK DIAGRAM

SUMMARY

VERSATILE: The HA7062D is a result of more than a decade of product development reflecting valuable customer feedback and Holzworth’s direct experience with measuring phase noise in our own manufacturing environment. The end result goes well beyond accuracy, reliability and speed... the reconfigurable front end allows users to tailor the analyzer for their specific measurement needs.

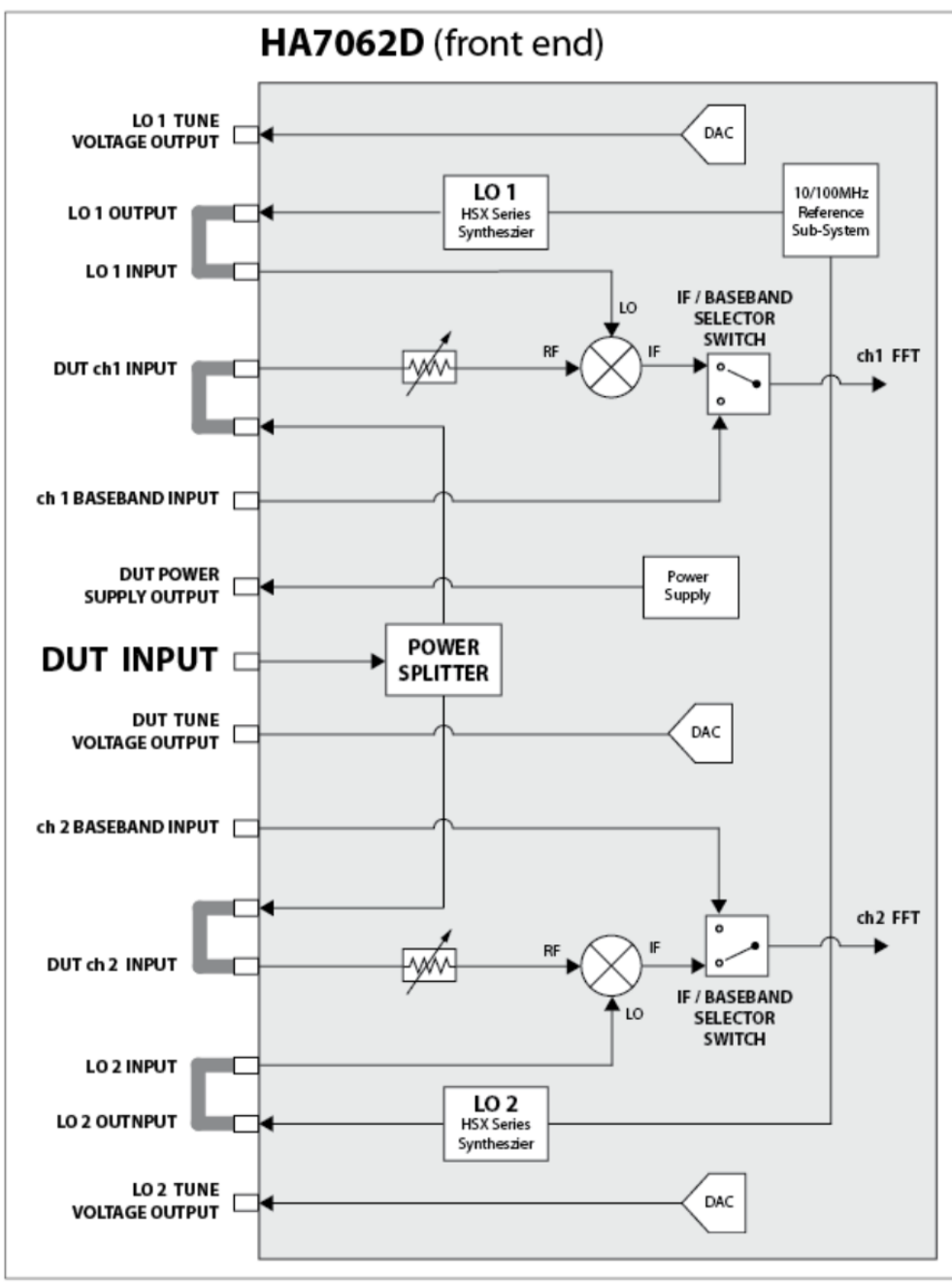

Figure 1: HA7062D Front End Block Diagram

SPECIFICATIONS - ELECTRICAL

The specifications outlined here capture the baseline performance and features that are currently available from the HA7062D phase noise analyzer. The highly reliable hardware is capable of additional functionality for custom requirements. Inquire with Holzworth Instrumentation or your local sales representative.

RF INPUT (DUT/LO)

DESCRIPTION	SPECIFICATION
RF Input Connector	2.92mm (female), 50 ohm
RF Input Frequency Range (standard)	10MHz to 26GHz
RF Frequency Extension (40GHz)	Available 2019
RF Input Measurement Level	-5dBm to +20dBm (Holzworth pre-amplifier available for <0dBm)
Input Damage Level	+22dBm
Input VSWR	< 2.0:1

PHASE NOISE MEASUREMENTS

DESCRIPTION	SPECIFICATION
RF Input Frequency Range	10MHz to 26GHz
RF Frequency Extension (40GHz)	Option: OPT-CC40 (available 2019)
RF Tracking Range	± 10 ppm (typical), ± 5 ppm (specified)
Offset Frequency Range	0.1 Hz – 100 MHz (ANSI z540.1)
Phase Noise Uncertainty 1 Hz to 1 kHz offset 1 kHz to 1 MHz offset 1 MHz to 100 MHz offset	± 4 dB (to be updated with improved uncertainty resulting from z540.1 calibration statistics) ± 2 dB (to be updated with improved uncertainty resulting from z540.1 calibration statistics) ± 2 dB (to be updated with improved uncertainty resulting from z540.1 calibration statistics)
Cross-Correlation Noise Floor	Refer to pages 7-10 for measured noise floor data

SPECIFICATIONS - ELECTRICAL (continued)
TABLE 1: MEASUREMENT SPEED (SAMPLE TIME) vs. MINIMUM OFFSET

1 Cross-Correlation							
128 Samples		256 Samples		512 Samples		1024 Samples	
-	-	0.1Hz	32s	0.1Hz	60s	0.1Hz	112s
1Hz	12s	1Hz	18s	1Hz	33s	1Hz	61s
10Hz	6s	10Hz	8s	10Hz	13s	10Hz	22
100Hz	4s	100Hz	5s	100Hz	7s	100Hz	10s
1kHz	4s	1kHz	4s	1kHz	6s	1kHz	8s
10kHz	4s	10kHz	4s	10kHz	5s	10kHz	7s
100kHz	4s	100kHz	4s	100kHz	5s	100kHz	6s
1MHz	4s	1MHz	4s	1MHz	4s	1MHz	5s

10 Cross-Correlations							
128 Samples		256 Samples		512 Samples		1024 Samples	
-	-	0.1Hz	186s	0.1Hz	370s	0.1Hz	732s
1Hz	67s	1Hz	96s	1Hz	189s	1Hz	371s
10Hz	19s	10Hz	28s	10Hz	52s	10Hz	100s
100Hz	6s	100Hz	8s	100Hz	13s	100Hz	20s
1kHz	4s	1kHz	5s	1kHz	7s	1kHz	9s
10kHz	4s	10kHz	4s	10kHz	6s	10kHz	8s
100kHz	4s	100kHz	4s	100kHz	6s	100kHz	7s
1MHz	4s	1MHz	4s	1MHz	5s	1MHz	6s

TABLE 2: CROSS-CORRELATIONS vs. PHASE NOISE IMPROVEMENT

Improvement factor: dB = 5logN (N = No. of correlations)

Number of Correlations	1	10	100	1,000	10,000
dB Improvement	0dB	5dB	10dB	15dB	20dB

INTERNAL TIME BASE (10MHz Reference)

DESCRIPTION	SPECIFICATION
Frequency Uncertainty / Stability	< ± 1Hz at 10MHz (±100 ppb) At time of shipment. Factory calibrated at +21C.
Frequency Temperature Effects	< 10ppb
Frequency Aging Rate	< 100ppb/yr
10MHz External Lock Range	± 20Hz (typical), ± 10Hz (specified). 10MHz is for frequency counters only.

SPECIFICATIONS - ELECTRICAL (continued)
POWER METER ACCURACY

PARAMETER	MIN	TYPICAL	MAX	COMMENTS
Input Power Meter Accuracy		±0.25dB	±2dB	

ANSI z540 CALIBRATION

DESCRIPTION	SPECIFICATION
Frequency Offset Range	0.1Hz - 100MHz
DUT Frequency Input Range	10MHz - 26GHz Standard 10MHz - 40GHz Optional

MEASUREMENT MODES

MODE	DESCRIPTION
Internal LO Mode	Internal synthesized LO sources. Auto tune and phase lock.
External LO Mode	User supplied LO sources. Auto calibration of LO sources and auto phase lock.
Additive Mode	External Signal Source required. Use with model HX5100-x Automated Phase Shifters
AM Noise Measurements	Measure AM Noise to observe potential AM to PM conversion
Pulsed Signal Measurements	Sample and Hold feature allows for non-triggered pulse measurements
Spurious Analysis Toolbox	Provides spurious performance data based on a user settable Spur Threshold

NOISE FLOOR MEASUREMENT SETUP

The unique architecture of the HA7062D allows for direct access to key internal modules in order to measure the actual noise floor of the analyzer at any given frequency vs. minimum frequency offset and number of correlations. As with Holzworth, competitive phase noise analyzers offer a cross correlation confidence factor, which is an only approximation based on the data being taken at the time. The confidence factor is not the actual noise floor of the system.

To perform a noise floor measurement, the internal power splitter is bypassed to directly access the phase detector (mixer) of each channel/core while measuring two non-correlated frequency sources at the frequency of interest. Refer to Figure 2, below.

NOISE FLOOR

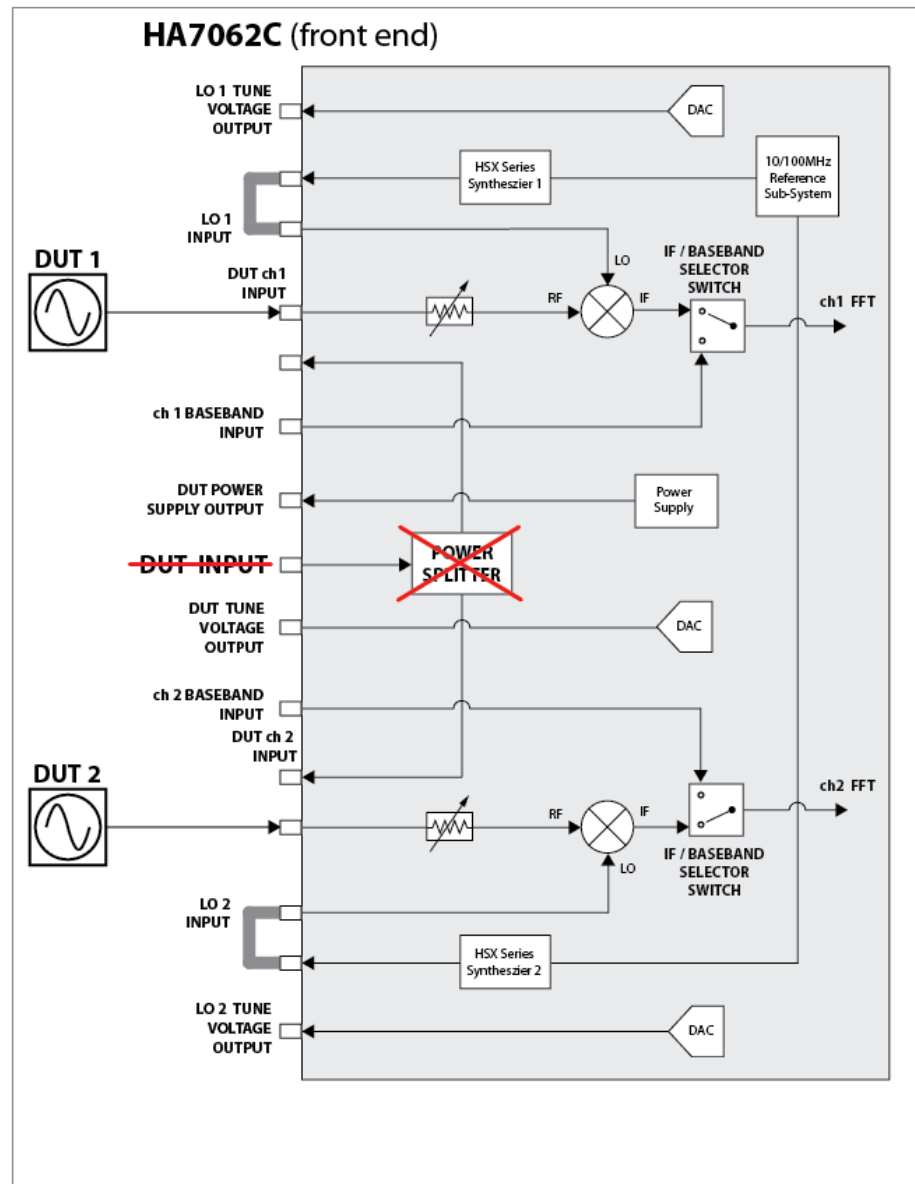

Figure 2: HA7062D Noise Floor Measurement Block Diagram

NOISE FLOOR DATA

The data contained in this section demonstrates the noise floor capability of the HA7062D at five different frequencies covering the base operating range of the instrument (10MHz, 100MHz, 1GHz, 3GHz and 6GHz). The three plots in each figure reflect the actual noise floor for 1, 10 or 100 correlations. Further improvement in the noise floor can be achieved by utilizing more correlations (refer to Table 2, located on page 5).

All data contained in this section was acquired using a minimum offset frequency of 1Hz. For reference, the data acquisition times for each measurement are as follows:

- 1 correlation: < 10s**
- 10 correlations: < 90s**
- 100 correlations: < 15 min**

NOTE: Setting the instrument to a higher minimum offset frequency will further improve the measurement speed.

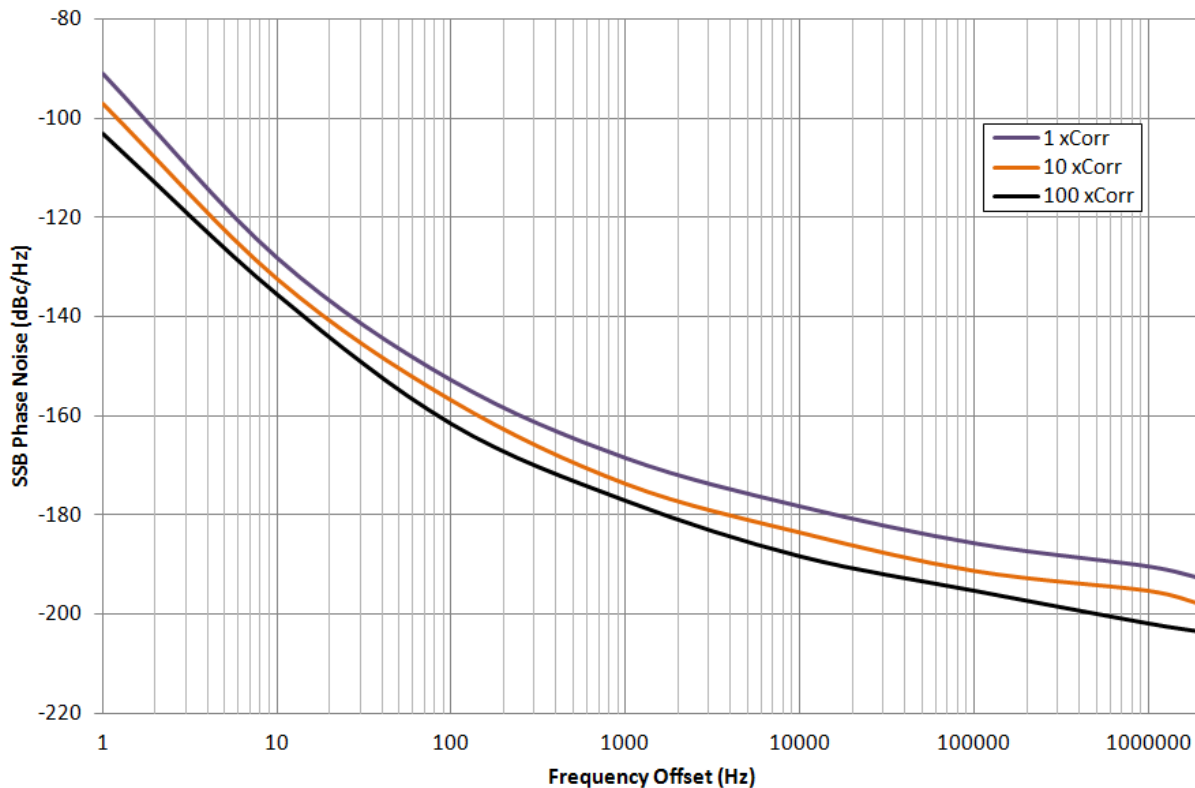

Figure 3: 10MHz Noise Floor Measurements

NOISE FLOOR DATA (continued)

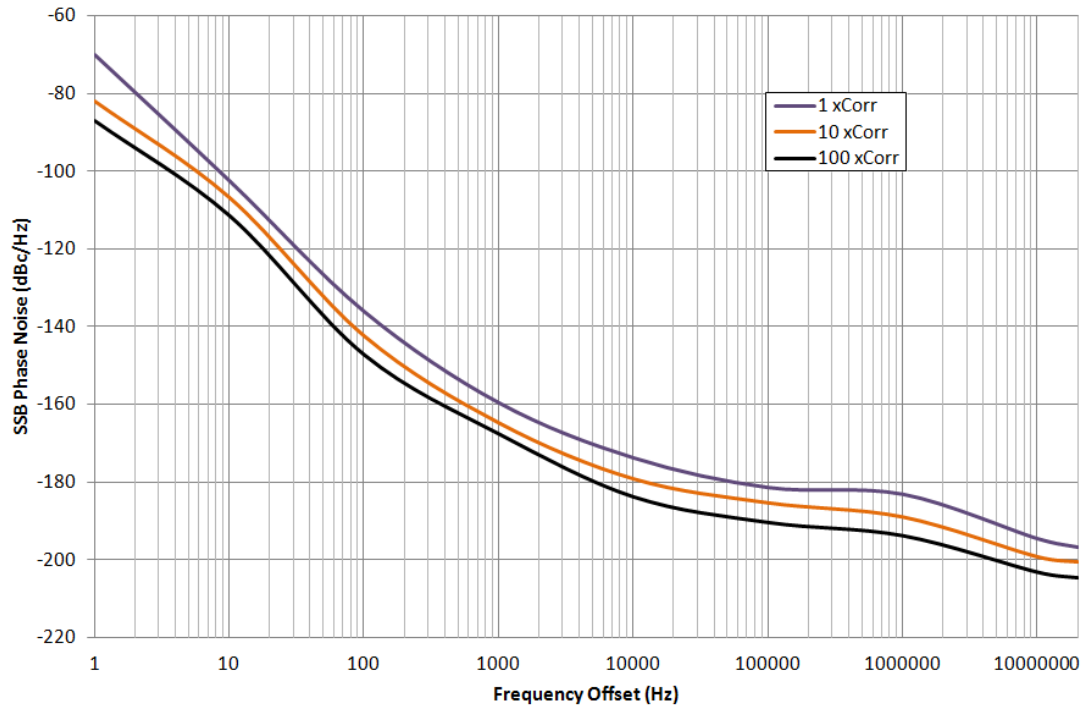

Figure 4: 100MHz Noise Floor Measurements

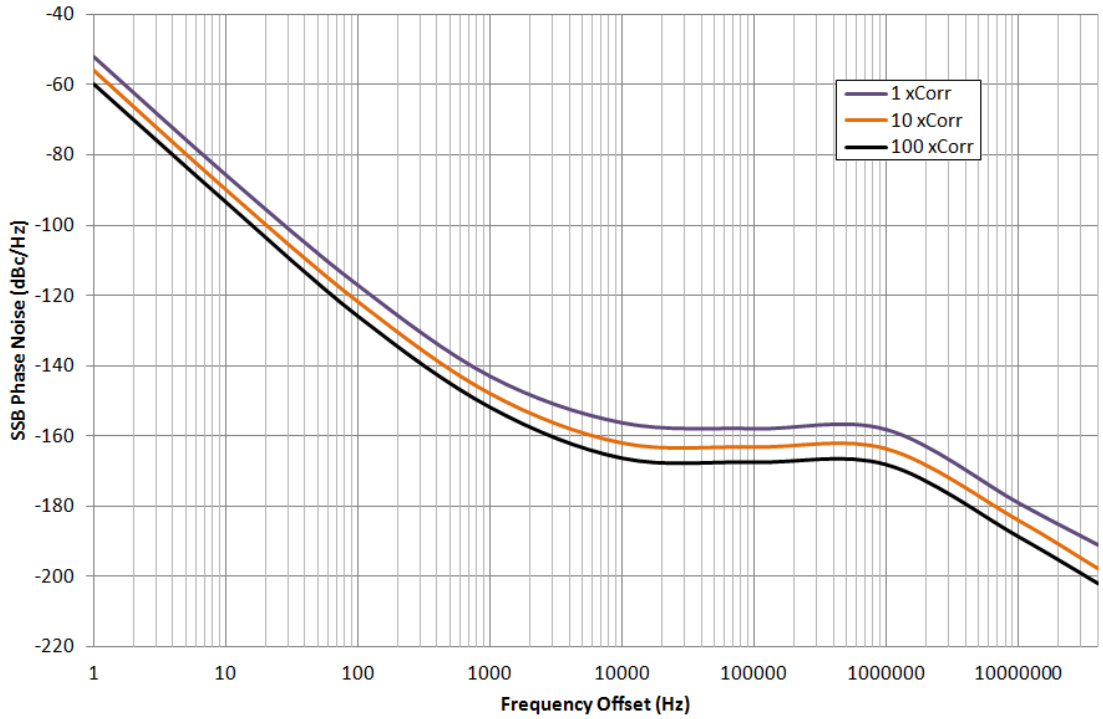

Figure 5: 1GHz Noise Floor Measurements

NOISE FLOOR

NOISE FLOOR DATA (continued)

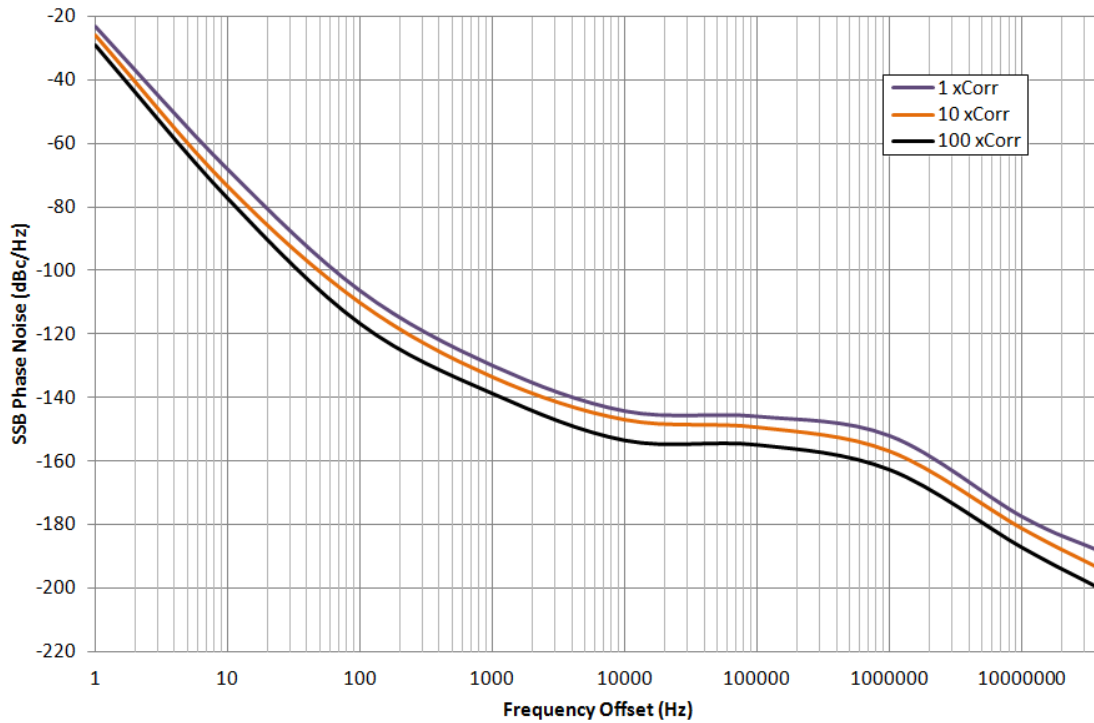

Figure 6: 3GHz Noise Floor Measurements

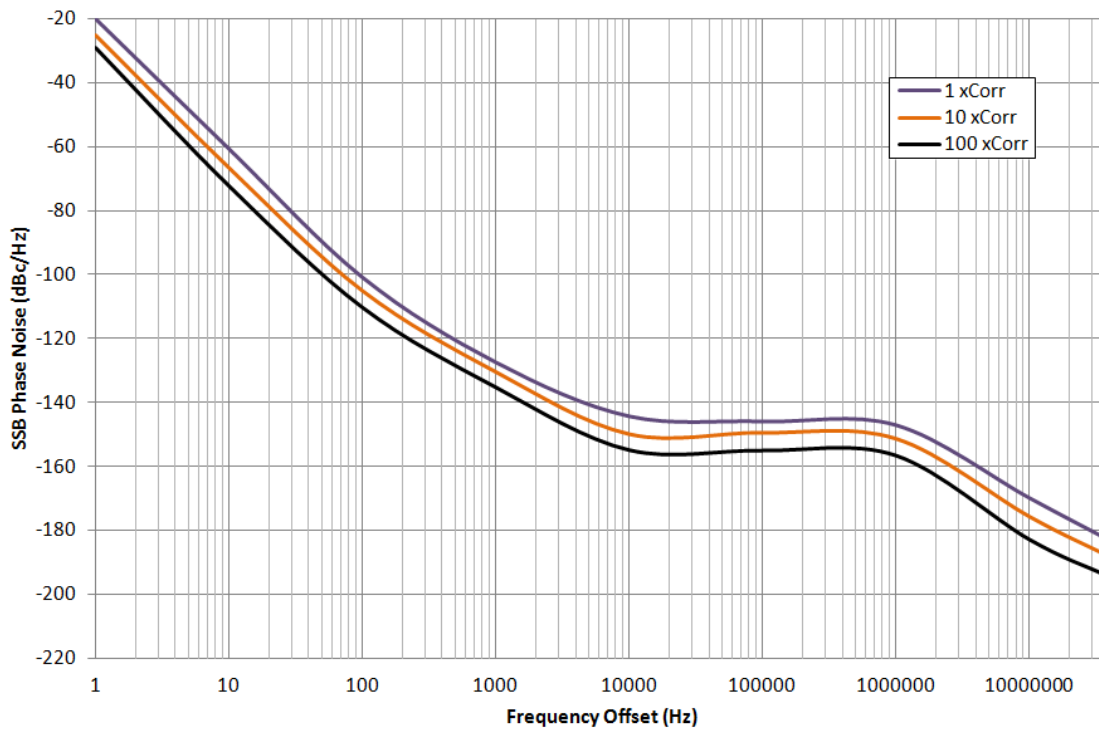

Figure 7: 6GHz Noise Floor Measurements

NOISE FLOOR

CONFIGURATION

FRONT PANEL

The HA7062D allows for a high level of measurement flexibility to accommodate different test scenarios by allowing the user access to various system input points. However, only the *DUT Input* port is necessary for making straight forward absolute phase noise measurements of a frequency source.

DESCRIPTION	SPECIFICATION
Front Panel Connector(s) Type	2.92mm, 50ohm
DUT Input Frequency Range (standard) Power Level Range Input Damage Level	10MHz to 26GHz 10MHz to 40GHz (OPT-CC40) -5dBm to +20dBm +22dBm
DUT Tune Voltage Voltage Tune Range Max Current	For Vcc control of some DUTs. -10V to +12V 5mA
DUT Power Supply Voltage Supply Range Maximum Current	Integrated power supply. 0V to +12V 250mA
LO1/LO2 Input(s) Frequency Range (standard) Power Level Range Input Damage Level	Connect to LO1/LO2 Output(s) for standard operation. 10MHz to 6GHz +7dBm to +12dBm > +22dBm
LO1/LO2 Output(s) Frequency Range (standard) Power Level Range	CW sources for residual measurements. Connect to LO1/LO2 Input(s) for standard operation. 10MHz to 6GHz (0.001Hz step size) 0dBm to +10dBm (0.01dB step size)
LO1/LO2 Tune Voltage Voltage Tune Range Max Current Tuning Sensitivity	For independent Vcc control of external LO sources during External LO Mode of operation. -10V to +12V 5mA TBD
DUT ch1/ch2 Input(s) Frequency Range (standard) Power Level Range Input Damage Level	Allows bypass of DUT power splitter for direct access to the phase detector of each channel. 10MHz to 6GHz 0dBm to +14dBm > +16dBm
ch1/ch2 Splitter Bypass Output(s)	Connect jumper cable to ch1/ch2 DUT Input(s) for standard operation.
ch1/ch2 Baseband Input(s) Frequency Range Power Level Range Input Damage Level	DC to 40MHz ± 1Vdc ± 2Vdc, or 50mA (whichever is greater)

CONFIGURATION (continued)

REAR PANEL

DESCRIPTION	SPECIFICATION
Reference Output Port Connector Type Output Frequency Output Level Output Waveform	SMA, 50ohm 10MHz \pm 10Hz +5dBm \pm 2dBm Sinusoid
10MHz Reference Input Port Connector Type Input Frequency Input Level	ONLY FOR FREQUENCY COUNTERS - DOES NOT AFFECT MEASUREMENT SENSITIVITY SMA, 50ohm 10MHz \pm 10Hz 0dBm to +10dBm (Sinusoid or Square)
AC Power Input Connector Type AC Input Rating	International Power Supply IEC 320-C13 90-260V _{AC} , 50-60Hz. Specify country at time of order for proper power cord.
Data I/O Interface Connectivity Storage	USB B-Type (virtual comm. port), Ethernet, RS-232, GPIB SD Card Reader

CONFIGURATION

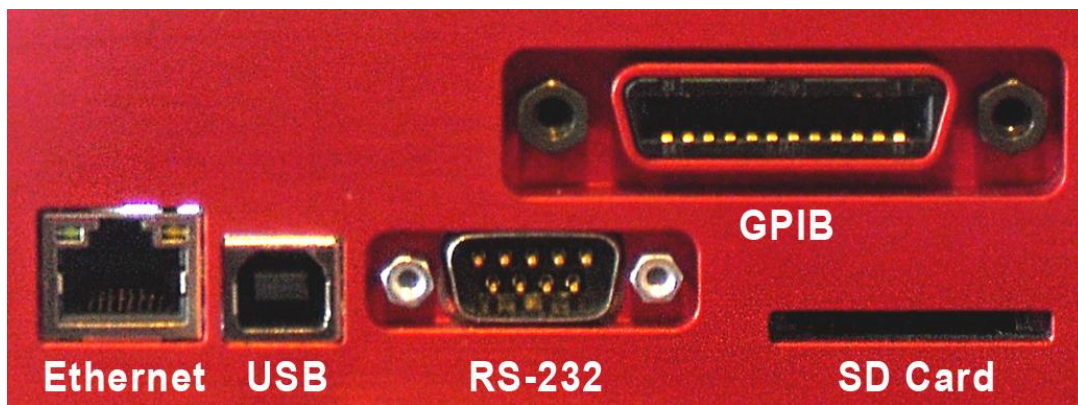
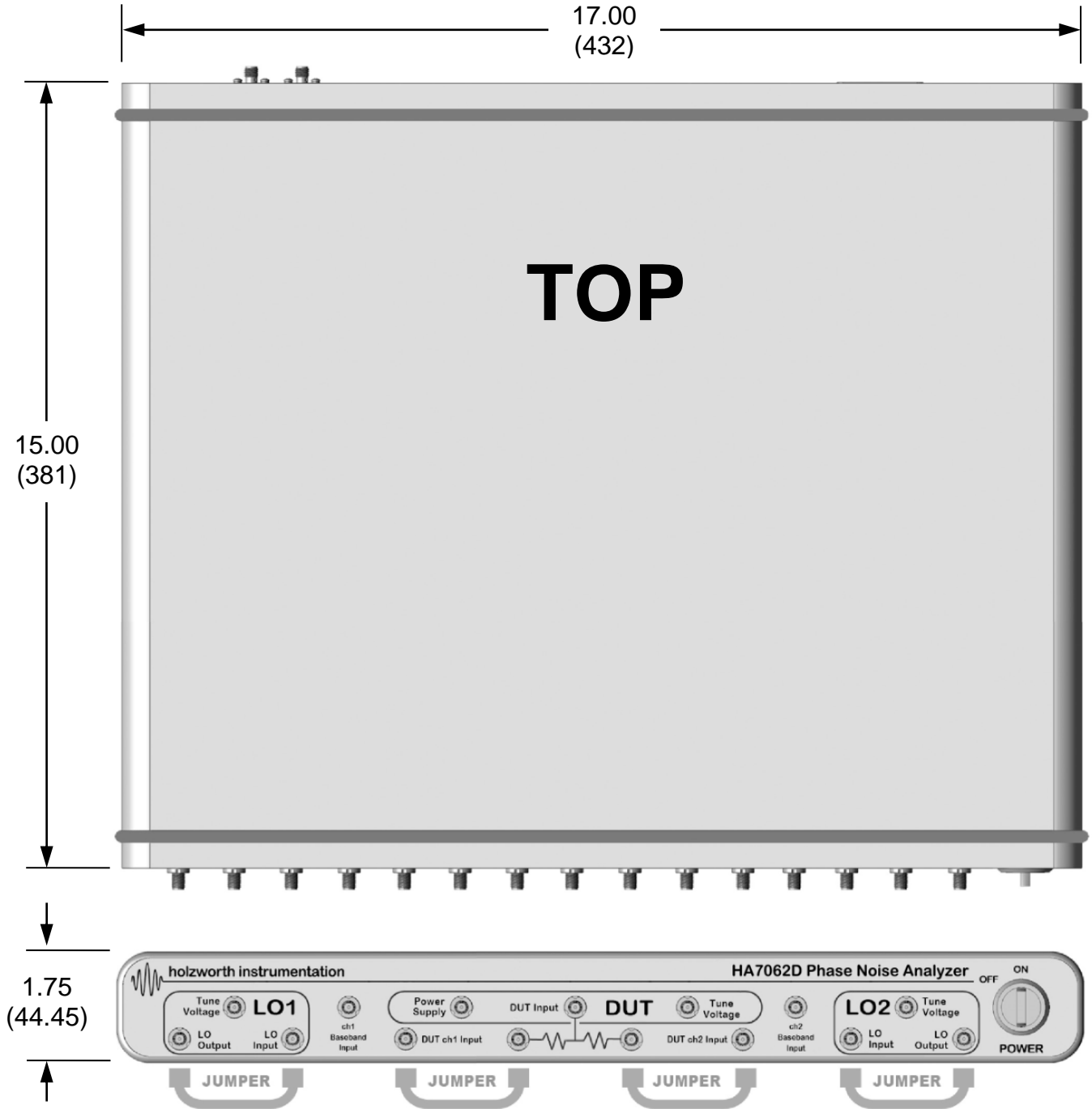

Figure 8: HA7062C Communication Ports

CONFIGURATION (continued)

MECHANICAL DIMENSIONS

The HA7062D has a 1U high, rack mountable chassis form factor. The fan-less design was adopted to eliminate the potential for microphonics. A universal rack mount bracket kit is an available accessory (Part No.: RACK-1U or RACK2-1U). Mechanical dimensions are listed in inches (and millimeters).



CONFIGURATION (continued)

AC POWER SUPPLY

The HA7062D utilizes an ultra-clean, international, switching power supply. Units ship with a country specific, AC supply cable. Please specify country of end use at the time of purchase.



CONFIGURATION

ENVIRONMENTAL

DESCRIPTION	SPECIFICATION (by design)
Operating Environment Temperature Humidity Altitude Vibration	+10C to +40C RH 20% to 80% at wet bulb temp. <29C (non-condensing) 0 to 2,000m (0 to 6,561 feet) 0.21 G-rms maximum, 5Hz to 500Hz
Storage (Non-Operating) Temperature Humidity Altitude Vibration	-10C to + 60C RH 20% to 80% at wet bulb temp. <40C (non-condensing) 0 to 4,572m (0 to 15,000 feet) 0.5 G-rms maximum, 5Hz to 500Hz

CONFIGURATION (continued)

OPTIONS & ACCESSORIES

Holzworth offers options and accessories to optimize the analyzer for an intended application. Specify all required options and/or accessories when requesting a quotation or placing a purchase order.

PART No.	DESCRIPTION	CLASSIFICATION
OPT-CC40	10MHz - 40GHz Cross Correlation Measurements	ACCESSORY
HX5100-x	Electronic Phase Shifter PAIR, Additive Measurements, 1 Octave Bandwidth, Specify fc	ACCESSORY
CASE-1U	Ruggedized Carrying Case with TSA security lock	ACCESSORY
RACK-1U	19" Rack mount bracket kit for HA7000 Series. 90 degree rear bracket.	ACCESSORY
RACK2-1U	19" Rack mount bracket kit for HA7000 Series. Straight rear bracket.	ACCESSORY

INCLUDED HARDWARE AND CERTIFICATIONS

Each standard product delivery includes specific, standard hardware and certifications.

TYPE	DESCRIPTION	COMMENTS
HARDWARE	HA7062D PHASE NOISE ANALYZER	DELIVERABLE
HARDWARE	AC Power Cord (7ft/2.1m). Specify country of end use.	DELIVERABLE
HARDWARE	Ethernet Cable (10ft/3m)	DELIVERABLE
HARDWARE	USB Cable (6ft/1.8m)	DELIVERABLE
CERTIFICATE	ANSI z540.1 CALIBRATION CERTIFICATE (0.1Hz - 40Mhz)	DELIVERABLE
WARRANTY	3 YEAR MANUFACTURER'S WARRANTY	NON-APPLICABLE
CERTIFICATE	CE COMPLIANCE CERTIFICATE <i>DIRECTIVE: 2004/108/EC, TEST STANDARD: EN 61326-1: 2006</i>	WEB DOWNLOAD
CERTIFICATE	RoHS COMPLIANCE CERTIFICATE <i>DIRECTIVE: 2002/95/EC</i>	WEB DOWNLOAD
CERTIFICATE	WEEE COMPLIANCE STATEMENT <i>DIRECTIVE: 2002/96/EC</i>	WEB DOWNLOAD

CONFIGURATION

HA7062D OPERATION

All data processing is performed internally on the HA7062D. Measurement settings can be changed using serial commands sent to the HA7062D via any of the included communication options (see *CONFIGURATION* on page 12). Measurement results can be read back directly from the instrument, eliminating the use of the GUI software. This capability provides unparalleled operational flexibility, ideal for ATE applications.

Purchase of an HA7062D includes access to the C++ based GUI for hardware operation and viewing/saving data. All software upgrades and functionality additions are freely available for the life of the instrument at no additional cost to the user.

HA7062D SOFTWARE

The HA7062D GUI offers an extremely user-friendly means to utilize the full functionality of the HA7062D on any Windows-based PC. Absolute, Additive, Jitter, AM Noise, and more can be performed using the intuitive software GUI. Refer to the software menu summaries on page 17.

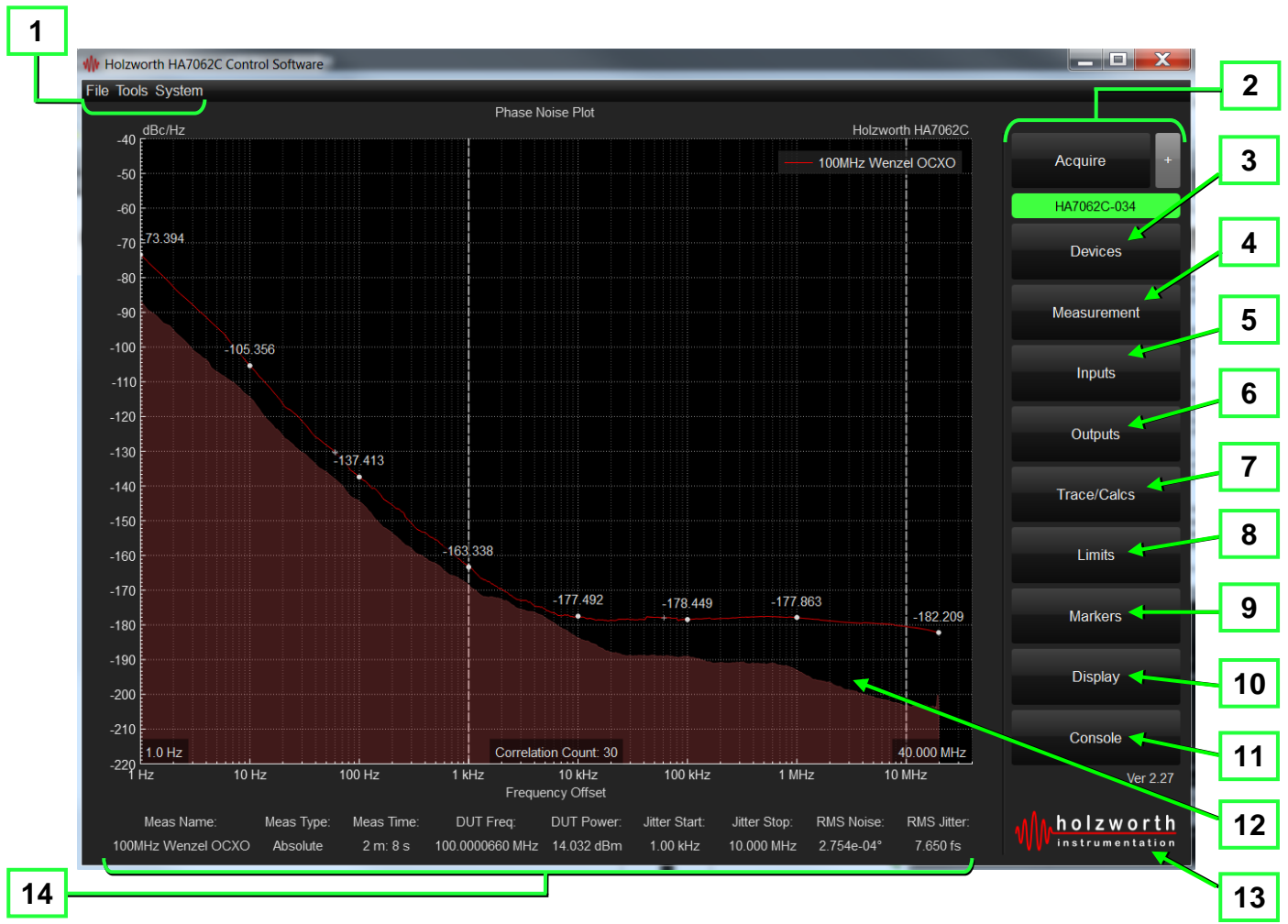

HA7062C SOFTWARE (continued)

The software menus indicated on page 16 are summarized as follows:

1. **File:** Save, load, export, import data; and generate reports. The report generator captures the current plot and any measurement statistics (see page 18).
Tools: Quick access to the Tune Voltage outputs on the analyzer and displays input frequency and power for either LO1, LO2, or the DUT port.
System: Create instrument setting presets (saving time for commonly used measurement setups), view/save measurement debug files, and manually perform firmware updates.
2. **Acquire / +:** The 'Acquire' button initiates/stops a phase noise measurement. When the '+' button is depressed, selecting 'Acquire' will overlay a new measurement to the existing data captured in the plot area with each new acquisition.
3. **Devices:** 'Devices' allows the user to view any HA7062D analyzer directly connected to the PC (USB or Ethernet) or over a LAN connection (Ethernet only) for multi-device control. Available devices are selected by part number/serial number.
4. **Measurement:** Make changes to measurement type, offset range, jitter parameters, number of correlations, *etc.*
5. **Inputs:** Used to verify DUT/LO power and frequency, calibrate and make adjustments for both internal and external LO sources.
6. **Outputs:** Provides tune control for the DUT Power Supply, DUT Tune Voltage, External LO Tune range and Internal LO power levels.
7. **Trace/Calcs:** Access to smoothing and spur removal functions to a data modify data markers. This sub-menu also contains the spurious analysis toolbox.
8. **Limits:** Apply test limit lines to the plot area for indicating pass/fail conditions.
9. **Markers:** Adjust the number of data markers, their locations and behavior.
10. **Display:** Provides access to plot data plot area modifications. Used to edit the x/y axis ranges, plot title, axis titles, trace names, plot export options, *etc.*
11. **Console:** The Console displays a log of instrument/measurement activity while also allowing the user to send commands directly to the instrument.
12. **Data Plot Area:** Displays acquired data: PM, AM, baseband, spurious, *etc.*
13. **Status Indicator:** The Holzworth logo shockwave doubles as a status bar/indicator while measurements are in progress. A measurement countdown timer is also displayed above the shockwave.
14. **Measurement Statistics:** Displays statistics of an active measurement or currently of a specifically selected data trace.

HA7062C SOFTWARE REPORT GENERATION

The automated report generation tool is a convenient feature for quickly generating a preformatted report that captures all traces and applicable data that is currently being displayed by the GUI. Each data trace actively contained in the plot area will be included in the report and color coordinated with its corresponding data.

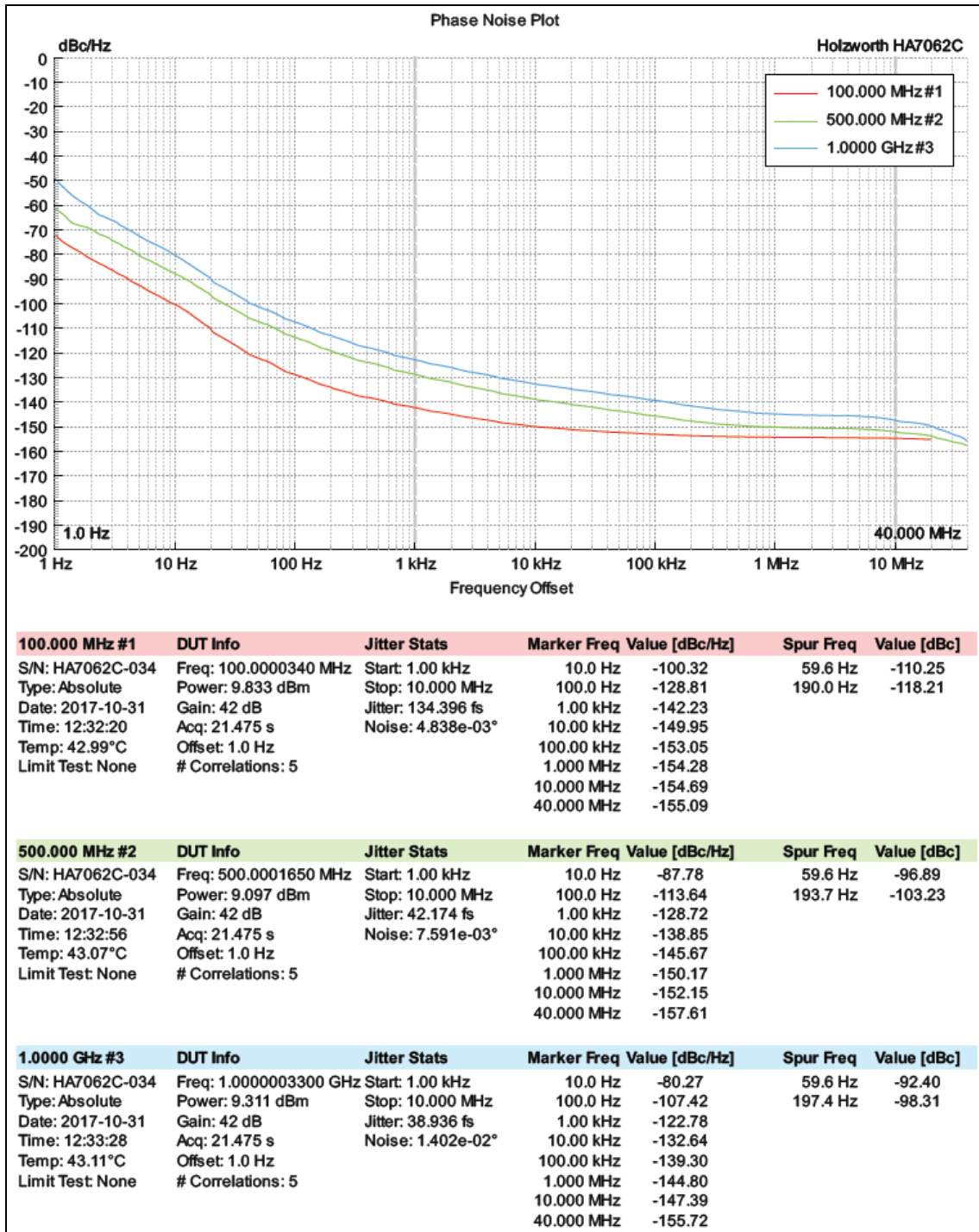



HA7062D

PHASE NOISE ANALYZER

3 YEAR WARRANTY

All Holzworth phase noise analyzer products come with a standard 3 year 100% product warranty covering manufacturing defects and workmanship. All product repairs and maintenance must be performed by Holzworth Instrumentation. Holzworth reserves the right to invalidate the warranty for any product that has been tampered with or used improperly. Refer to Holzworth Terms & Conditions of Sales for more details.

Holzworth products are proudly designed and manufactured in the USA.



ООО «4TECT»
Телефон: +7 (499) 685-4444
info@4test.ru
www.4test.ru